

1/2 x 1/2 x 1" LG
POSITIONING STRIPS

ROOF—LOOKING DOWN AT
TOP

LOOKING AT
SIDE

REAR END PIECE

RIGHT SIDE PIECE
(OUTSIDE)

LEFT SIDE PIECE
(INSIDE)

Summary: This sheet shows suggested dimensions for a building to cover the control unit.

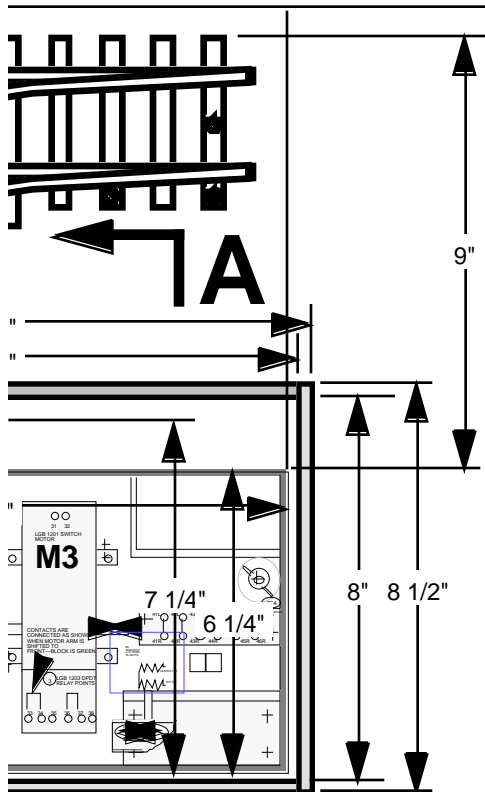

TOP VIEW — ROOF
REMOVED

IMPORTANT: VERIFY THAT THESE INSIDE DIMENSIONS ARE ADEQUATE FOR YOUR PARTICULAR UNIT

TRACK
THIS SIDE

