

- CONTACTS POINTING RIGHT (T8, T6, T4) ACTUATE RELAY ARMS & TRACK SWITCHES TO THE RIGHT
- CONTACTS POINTING LEFT (T7, T5, T3) ACTUATE RELAY ARMS & TRACK SWITCHES TO THE LEFT

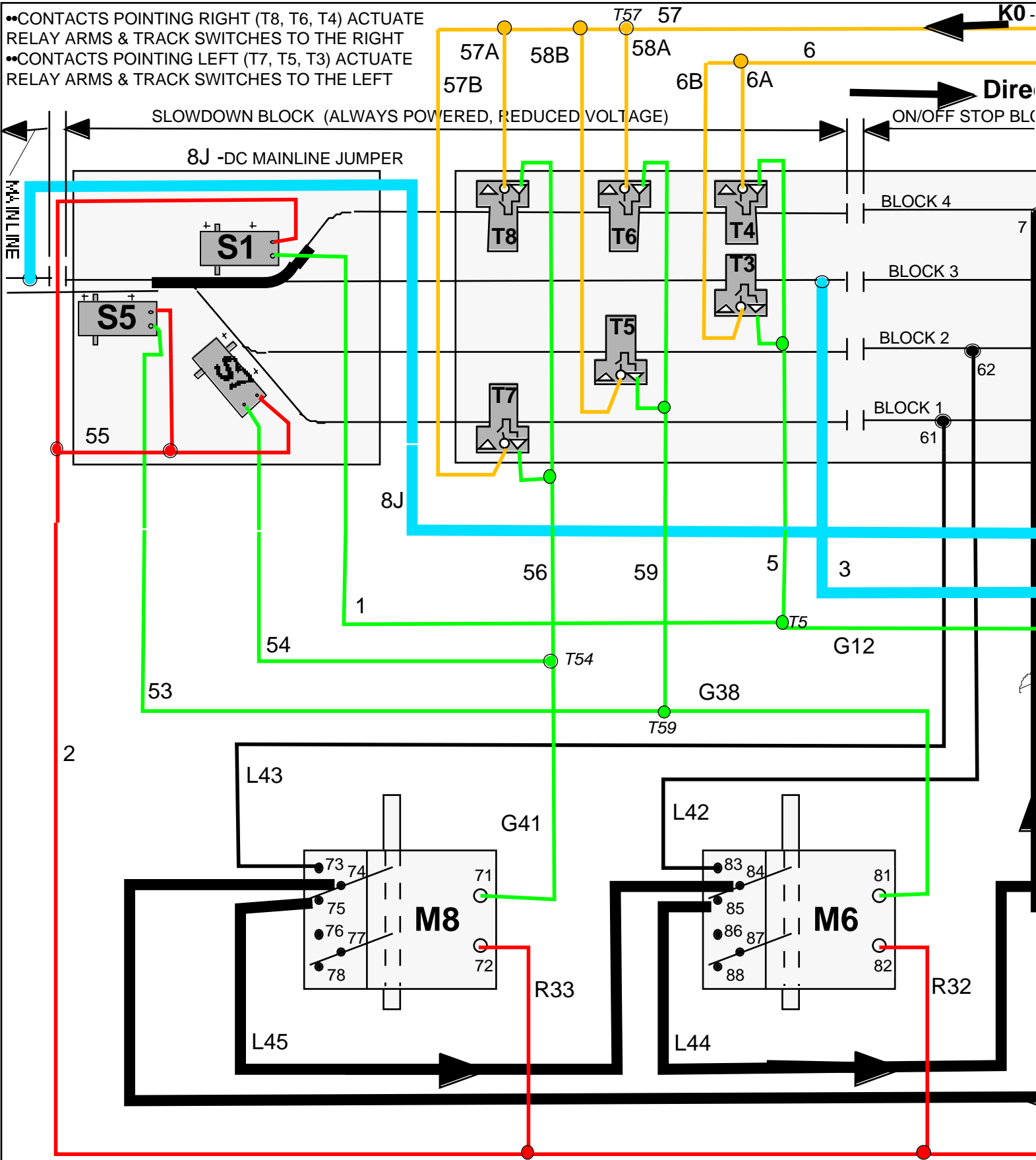

**COLORS:**

- BLUE = DC (+) UNSWITCHED (INPUT)
- BLACK = DC (+) SWITCHED (OUTPUT)
- YELLOW = AC (+) UNSWITCHED (INPUT)
- GREEN = AC (+) SWITCHED (OUTPUT)
- RED = AC (-) GROUND

- 3, 8, 8J, B1, B2, B5, B8
- 4, 7, 61, 62, L1, L13, L14, L42, L43, L44, L45
- 6, 10, 11, 57, 58, Y1, Y24, Y35
- 1, 5, 9, 12, 53, 54, 56, 59, G2, G12, G38, G41
- 2, 55, R2, R12, R26, R32, R33

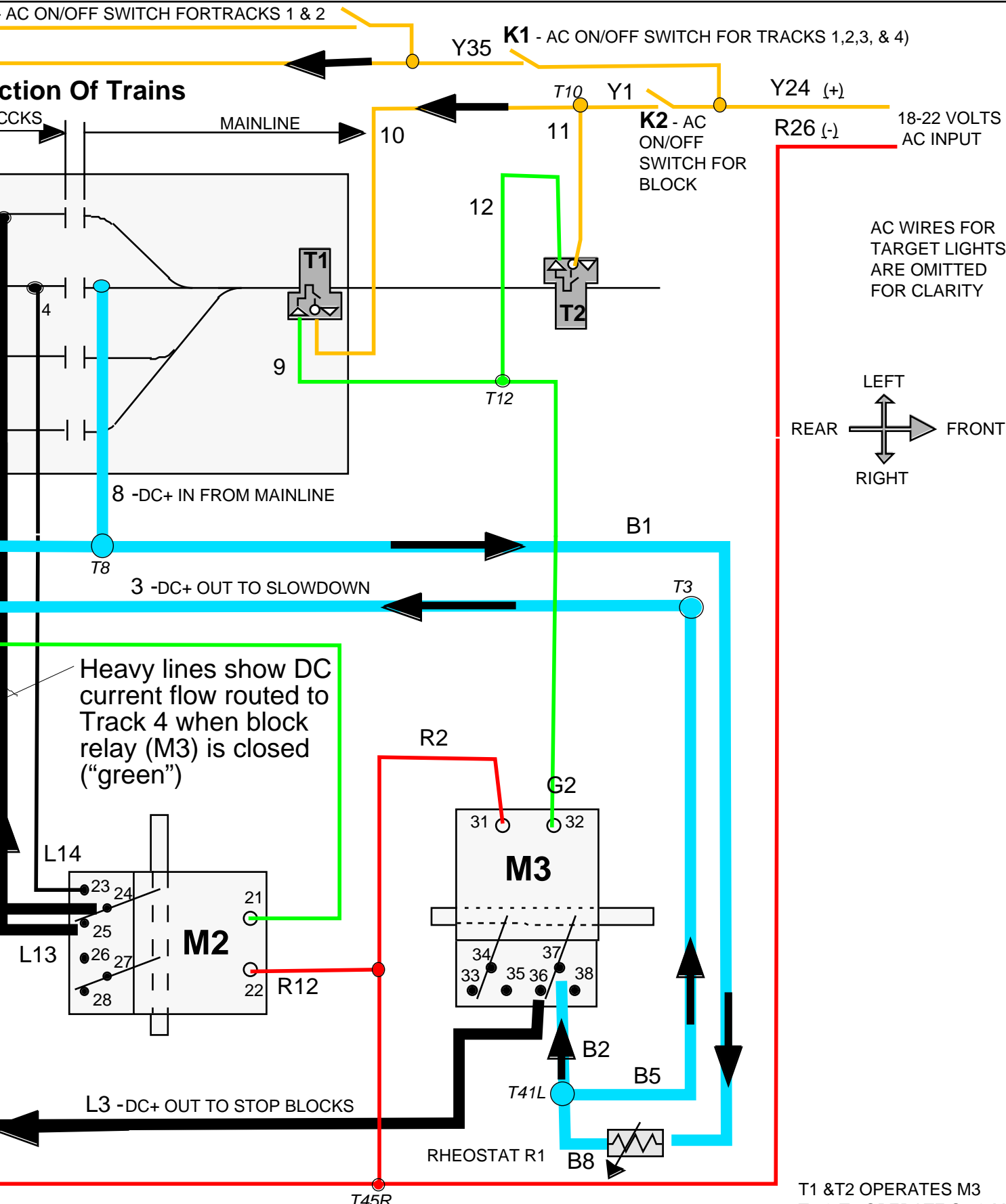

SOME TERMINALS ARE SHOWN, AS INDICATED BY NUMBERS IN ITALICS, EXAMPLE: T3, T8, T41L, T45R, ETC.

T1 & T2 OPERATES M3  
 T3 & T4 OPERATE S1 & M2  
 T5 & T6 OPERATE S5 & M6  
 T7 & T8 OPERATE S7 & M8